



ELECTRIC VEHICLES



Owner's Manual and Service Guide

**Roadster:
Roadster 2+2-AC and Roadster 4+2-AC**

Thanks for buying the Star EV Roadster. This manual contains information you will need for proper operation, maintenance, and care of your Roadster. A thorough understanding of these simple instructions will help you to obtain maximum enjoyment from your new Star EV.

If you have any questions about the operation or maintenance of your Roadster, please consult your Star EV dealer.

Read and understand this manual completely before operating your Star EV.

This manual should be considered a permanent part of your Roadster and should remain with the car when lending or resold.

Table of Contents

Vehicle Specifications	4
Operation	4
User Information	6
Driver Information	
Driving	7
New Vehicle Inspection	8
Maintenance	
Battery Maintenance	9
Brake System Maintenance	11
Steering System Maintenance	11
Motor Maintenance	11
Lubrication Maintenance	11
Maintenance Schedule	12
Troubleshooting	13
After-Sale Service	14
Electrical Diagrams	14

1: Vehicle Specifications

Roadster Roadster 2+2-AC and Roadster 4+2-AC

Passengers	4 of 6 (2 facing backwards on both)	Body Material	Fiberglass
Battery System	Eight 6 V (48 V) batteries, Trojan T-105	Front Suspension	Leaf spring and shock
Motor Power	7 hp AC motor	Steering System	Rack and pinion
Controller Power	450 A Curtis AC controller	Brake System	2+2: Rear drum 4+2: Four-wheel hydraulic
Top Speed	19.5 mph (20-25 mph if street legal)	Tire Size	20x9-12 DOT tires
Load Capacity	2+2: 800 lbs / 4+2: 1,080 lbs	Tire Pressure	40 psi
Dimensions	2+2: 140" x 53" x 46" (L x W x H) 4+2: 167" x 53" x 50" (L x W x H)	Wheel Type	12" machined aluminum
Weight w/ Batteries	2+2: 1440 lbs / 4+2: 1620 lbs	Roof	Optional (71"H)
Ground Clearance	5.9"	Windshield	Fixed tempered glass
Turning Radius	2+2: 14 ft / 4+2: 17 ft	Drive Train	Direct rear drive with 10.25:1 ratio
Wheel Base	2+2: 67" / 4+2: 116"	Voltage Reducer	20 A, 48 V to 12 V reducer included
Top Climbing Grade	25%	Warranty	Four year limited warranty, two year bumper-to-bumper warranty (less wear items)

2: Operation

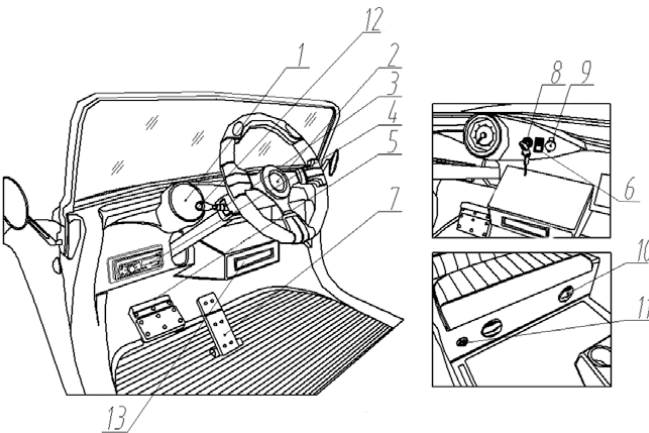

1. Dashboard
2. Steering wheel
3. Combination switches
4. CD player (optional)
5. Brake pedal
6. Forward/reverse switch
7. Accelerator pedal
8. Key switch
9. Cigarette lighter
10. Speakers (optional)
11. Charger socket
12. Turn signal lever, horn and light switch
13. Cup holders

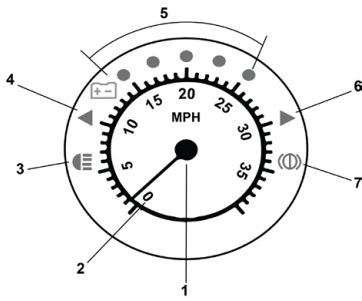

1. Speed gauge mounting point
2. Speedometer
3. Lights on indicator
4. Left turn signal indicator
5. Power display
6. Right turn signal indicator
7. Brake light

Notes:

- Low battery voltage alarm light: Red when battery voltage is low.
- Turn signal: The turn signal lever has a button on the end. Push in to sound horn; pull lever back to turn on lights.
- High beam: The indicator will light up yellow when high beams are on.

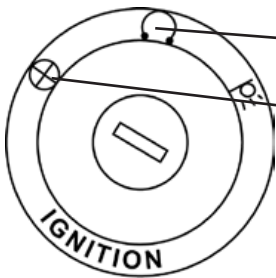

- On: All power systems are on when in this position.
- Off: key can only be removed in this position.

WARNING: Do not take out the key when the vehicle is running. Do not leave key in ignition to avoid theft or accidental operation by a child.

Forward/Reverse switch: The switch has three positions. The vehicle goes forward when FWD is pressed down and backward when REV is pressed down. When the switch is centered, vehicle is in the neutral position. **WARNING:** Do not shift between forward and reverse when vehicle is running or damage to the transmission and/or motor can occur.

WARNING: Before leaving the cart, put the Forward/Reverse switch in neutral. Before moving forward or reverse the parking brake should be released to prevent serious damage to the brake system and related parts.

Turn signal: Push lever up to illuminate right turn signal; push down to illuminate left turn signal.

Headlight switch: Pull turn signal lever into back position to turn lights on. Push back forward for lights to be in off position.

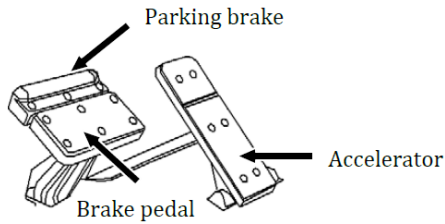

Horn: Press down the horn button on the end of the turn signal lever to engage horn.

Parking brake: The parking brake will click and lock in the down position to indicate that the parking brake is engaged. Lightly push on the accelerator pedal to release the parking brake.

Braking: Depress the brake pedal to brake.

Accelerating: Press the pedal and control speed by force applied to the pedal.

Charging, Charger Socket: Plug the larger round plug end into the vehicle charge port. Plug the power cord end into a standard outlet (110 V) to begin the recharging cycle. See charging section (p. 11).

Cigarette lighter: Plug in any 12 V DC accessories into outlet. Ideal for use of MP3, phone chargers, mini fans and other accessories.

3: User Information

Read all vehicle specifications, and use the vehicle according to manufacturer recommendations.

Do not modify the vehicle without manufacturer's approval. Any modifications will affect the function, safety, and warranty of vehicles.

Any replacements of spare parts by an authorized STAR EV dealer (i.e., changing batteries, tires, seats, etc.) shouldn't affect the safety requirements. Do not attempt to lift the suspension of this vehicle as serious injury could occur and the vehicle will no longer be warranted by the manufacturer.

This is a low speed electric vehicle, and should be used on approved roads and meet the road regulations. Carefully review the laws for golf car and low speed vehicle use

in the city and state you are operating the vehicle in.

4: Driver Information

It is recommended that only persons with a valid motor vehicle driver's license be allowed to operate the vehicle.

The driver should pay close attention to road conditions, pedestrians and other vehicles on the road.

Remind passengers to buckle seat belts and keep arms and legs inside the vehicle at all times when it is moving.

Report accidents to your insurance company.

The driver should not modify, add or remove any parts of the vehicle. Do not add or install any optional steering wheel unless they are designed to fit this vehicle. See authorized dealer in your area for help.

The driver should operate vehicles in approved areas.

Driving

Operation Procedure

1. Insert the key and turn it to ON position.
2. Press the green forward switch (or reverse).
3. Release the parking brake by lightly pressing on the accelerator pedal. The speed will increase as pedal is pressed downward.
4. When stopping the vehicle, release the accelerator pedal and depress the brake pedal slowly. Then push down the parking pedal after stopping to engage the parking brake.

Safety

- Release the parking pedal before driving to avoid any damage to the brake shoes or motor.
- Do not depress the accelerator pedal too aggressively or frequently or it will shorten the life of the drive train and components.
- Do not start, stop, or turn at high speeds.
- Do not pass other vehicles traveling in the same direction at intersections, blind spots, or at other dangerous locations. Follow all traffic laws.
- Avoid running over loose objects, potholes, and bumps to avoid damage to the vehicle and possible injury to passengers.

- Please observe and obey all traffic regulations, including the passenger and weight capacity requirements, authorized speed limits, and other regulations.
- Keep a clear view of the path of travel. Observe other traffic and pedestrians, and maintain a safe distance, based on speed of travel, from a vehicle ahead.

Driving on hilly terrain

- Ascend or descend grades slowly.
- Do not turn around when driving on a sharp incline or decline. Be careful when driving near to the edge of the slope.

Parking safety tips

- Park the cart on flat and solid ground.
- Depress the brake pedal. Keeping the direction switch in neutral position, turn off the ignition switch and take out the key. Make sure that the brake pedal is locked in park. You will hear a load click when the parking brake is engaged.
- Keep the vehicle stored inside of a garage if possible. Don't leave it outside in snow or rain, as water can get into the electrical system which will cause damage. Check with your local dealer about the advantages of a car cover if you cannot park the vehicle in a garage, car port, or similar covering.

New Vehicle Inspection

Before a new vehicle is put into operation, the items shown below must be performed.

1. Check status of each spare part, especially the nut on the steering wheel and braking system.
2. Check for any leakage problems with the steering system, turning system and transaxle.
3. Check the water level of each battery. Maintain proper levels (see Trojan battery guide) and **do not overfill battery cells.**
4. Check if tire inflation is correct. Low pressure will lead to difficulty turning and bumpy riding. Keep the normal air pressure for the tire to prevent premature wear. Recommended tire pressure is 30 PSI.
5. Check for any worn items between the wiring and other locations where parts rub against each other.

5: Maintenance

- Turn off the electricity, take out the key and push down on the parking brake.
- When working underneath vehicles, please use jack and triangle wood to fix the front and rear wheels, in order to avoid accidents.
- Keep the maintenance area clean and safe.
- Please perform vehicle maintenance according to safety guidance. Refer to STAR EV preventative maintenance schedule or visit an authorized dealer.
- Maintain the ventilation of working sites.
- Check and maintain safe working conditions. Check and maintain the braking, steering, speed direction control system, emergency facilities, head/rear lights, controller, and safety equipment.
- Check the battery cover caps to ensure they are snapped into place.

Battery Maintenance

- The batteries for this vehicle have high current, high capacity, and a long lifetime. To keep the vehicle in good performance, it is very important to maintain it in the correct procedure.
- The connectors on the batteries are the output connectors. Keep the area clean and dry, with no foreign matter or dust on it. Proper care will ensure batteries' performance and longevity.
- **WARNING:** Do not use tap water when filling cells. Use distilled water only!
- Check the height of the electrolyte periodically. Check it once per week in summer and once every two weeks the rest of the year. Standard height level is 10-15mm (½") higher than the battery plate. If is too low, please add the recommended distilled water.
- Keep the wiring well-connected. After using the vehicle initially for 2-3 days, the completed inspection for all connectors should be carried out. Inspect the vehicle once a week following. Any loose or rusty connectors should be fixed. Loose or rusty connectors can cause high temperature, damage, or possible sparking.
- **NOTE:** Don't over-tighten terminals!
- Charge the battery immediately after discharge, or it will affect the battery life. Charge the batteries that are in long storage or non-fully charged separately.
- Keep the filling-water container clean, so no impurities will be put into the battery.
- When the environment temperature is under -40° F, the density of the electrolyte after charging is 1.28 - 1.29 g/cm³. If it is more than 1.30 g/cm³, the battery can be damaged badly. Add water immediately to keep the elec-

trolyte value to normal. If the battery discharges by 80% (the electrolyte is between the range 1.13 - 1.15 g/cm³), charge it immediately. At this range the vehicle can only last 2 - 3 mi. Don't discharge any longer, or it will damage the battery.

- Charge the battery fully before storage. Charge it at least once a month for 24 hours. Discharge the batteries and charge it once again before use.
- See an authorized dealer for further help and maintenance.

Charging

- In order to optimize battery life, please use the recommended charger to recharge the batteries.
- Keep the key switch in OFF position during charging.
- Keep the charger in a cool, dry location and avoid moisture.
- Charging should be monitored.
- **NOTE:** When disconnecting the charger, be sure to unplug cord from AC power source first then unplug cord connected to vehicle.

Battery Replacement

1. Replace the batteries immediately when approaching the end of the battery's life. The capacity of a battery at the end of its life will decrease quickly and won't meet the standard range (miles on full charge). Consult with the supplier or dealer for a detailed battery replacement.
2. Remove battery tie-downs and cables. Lift out batteries with a commercially available lifting device. If the batteries have been cleaned and any acid in the battery rack area has been neutralized as recommended, no corrosion to the battery racks or surrounding area should be present. Any corrosion found should be immediately removed with a putty knife and a wire brush. The area should be washed with a solution of sodium bicarbonate (baking soda) and water and thoroughly dried before priming and painting with a corrosion resistant paint.
3. The batteries should be placed into the battery racks and the battery tie-downs tightened to 45 - 55 in. lbs. (5 - 6 Nm) torque to prevent movement but not tight enough to cause distortion of the battery cases.
4. Inspect all wires and terminals. Clean any corrosion from the battery terminals or the wire terminals with a solution of sodium bicarbonate (baking soda) and clean with a wire brush. **WARNING:** To prevent battery explosion that could result in severe personal injury or death, extreme care must be used with aerosol containers of battery terminal protectant. Insulate the metal container to prevent the metal can from contacting battery terminals which could result in an explosion.
5. Use care to connect the battery wires as shown. Tighten the battery post

hardware to 50 - 70 in. lbs. (6 -8 Nm) torque. Protect the battery terminals and battery wires with a commercially available protective coating.

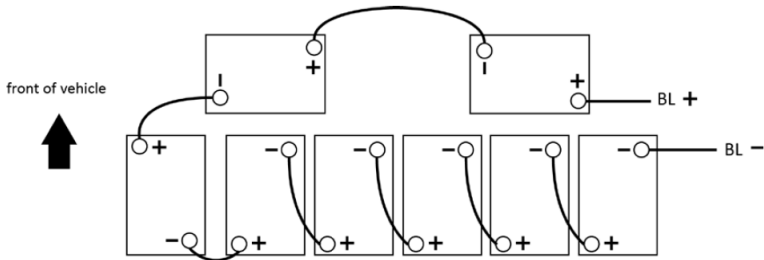

Battery Connections

Brake System Maintenance

Adjust the gap between the brake drum and brake shoes. Dial up the adjusting ratchet wheel of the brake drum until the wheel cannot turn freely, then dial down the ratchet wheel 7 - 8 teeth.

Steering System Maintenance

Check if there is any damage to the dust cover of the tie-rod. A broken dust cover will let water in and damage the tie-rod, and the steering system will not be flexible. Replace a new one immediately once a worn one is found. Make sure the front wheel toe-in is between 3 - 5 mm (1/8 - 3/16"). If it exceeds this value, adjust the tie-rod screw stem.

Motor Maintenance

The drive motor is an AC motor. Keep the motor surface clean at all times. Clean the surface with a dry cloth. Avoid any water contact inside motor.

Lubrication Maintenance

- Check the brakes once a month. Fill it full if brake fluid is low in master cylinder. The front hub, front wheel bearing, brake system, and steering system should be filled once every year with #3 general lithium based lubricant.

- The gear oil should be changed once a year. User can choose gear oil according to the climate. (Summer: GL-4 90, Winter: GL-80W/90)
- Replace the grease for the rear axle once a year, using recommended oil type GL-5 90 and GL-5 80W/90. Fill the level to 1.2 liters (40 oz). When changing, first twist down the oil plug to discharge the gear oil. Clean the oil plug and replace it, then inject the new gear oil.

Maintenance Schedule

Item	Weekly	Monthly	Quarterly
Check tire pressure	<input checked="" type="checkbox"/>		
Check tires for abrasions	<input checked="" type="checkbox"/>		
Check tightness of the bearing bolt and the tire nut	<input checked="" type="checkbox"/>		
Tire rotation			<input checked="" type="checkbox"/>
Check braking and the parking function		<input checked="" type="checkbox"/>	
Check brake tube for leakage		<input checked="" type="checkbox"/>	
Check if brake shoes are worn			<input checked="" type="checkbox"/>
Check if steering wheel works freely			<input checked="" type="checkbox"/>
Check brake pump	<input checked="" type="checkbox"/>		
Check tightness for the turning ball joint and rod		<input checked="" type="checkbox"/>	
Check nut on the steering rack's spindle		<input checked="" type="checkbox"/>	
Check tightness of steering rack and bracket		<input checked="" type="checkbox"/>	
Inspect and adjust front wheel's toe-in			<input checked="" type="checkbox"/>
Checking tightness of front absorber and helix spring			<input checked="" type="checkbox"/>
Check height of electrolyte	<input checked="" type="checkbox"/>		
Check density of electrolyte	<input checked="" type="checkbox"/>		
Check if the battery's pole is loose		<input checked="" type="checkbox"/>	
Clean battery pole by water		<input checked="" type="checkbox"/>	
Check light and relay performance		<input checked="" type="checkbox"/>	
Clean and fix wiring connector		<input checked="" type="checkbox"/>	
Check and adjust front tire's bearing		<input checked="" type="checkbox"/>	
Check or replace transaxle		<input checked="" type="checkbox"/>	
Check performance of gearbox and bearing		<input checked="" type="checkbox"/>	
Check motor's bolts and nuts		<input checked="" type="checkbox"/>	
Clear and lubricate front wheel bearing		<input checked="" type="checkbox"/>	
Checking motor bearing		<input checked="" type="checkbox"/>	
Lubricate other parts (use general oil)		<input checked="" type="checkbox"/>	

6: Troubleshooting

Problem	Possible Reason	Processing Methods
Cart cannot move	Operation procedure is wrong	Refer to user manual
	Wiring connector is corroding	Cut off the power, remove the nut, clean the connector and replace the nut
	Battery power is low	Charge the battery
	Direction switch is damaged	Replace part
	Accelerator is damaged	Replace part
	Direction contactor is damaged	Replace part
	Wiring is loose	Repair or replace parts
Vehicle moves slowly and/or stops when climbing	Vehicle is overloaded resulting in the shutting off the controller when temperature reaches 167° F	Lighten the load of the vehicle to decrease the temperature
Releasing the accelerator pedal does not slow down the vehicle	The spring for the accelerator pedal is broken and the pedal cannot reposition	Shut off the ignition lock, step on the parking pedal ,then contact with the supplier
No indication (LEDs) on the dashboard	Parts are loose	Lock the inserted parts
	Fuse is burned out	Replace the fuse
Bumpy riding	The tire pressure is unbalanced	Correct the tire pressure
	The front and rear wheel are not aligned	Correct the assembly of the wheels
Turning is difficult	Tire pressure is too low	Inflate tires
	Shaft needs lubrication	Add lubrication
	The direction shaft pin or joints are damaged	Replace parts
Turning excessively	Tie-rod is damaged	Replace part
	Steering rack has not been adjusted well or abased	Adjust or replace
	The direction shaft is loose	Tighten direction shaft
Lack of power, slow response	Low battery power	Charge the battery
	Damaged drive gear	Replace
	Speed control system is faulty	Maintain speed control system
Rear bearing is leaking oil	Axle of the tire or the washer is damaged	Replace parts
	Too much oil	Reduce oil quantity

Problem	Possible Reason	Processing Methods
Abnormal noise	Drive gear or the bearing is damaged	Tighten
	Bearing of front or rear suspension is damaged	Replace part
	Wheel screw is loose	Replace part
	Motor's bearing is damaged	Keep clean
Low braking power	Brake drum is damaged	Replace part
	Brake shoe is not clean	Keep clean

These possible causes are just for your reference and do not include all causes that result in these listed issues.

7: After-Sale Service

Star EV has authorized local dealers that will provide the friendly service and technical support for end users. Be sure to visit www.starev.com to find a dealer in your area.

Users can report faulty problems by telephone, fax and email. Keep Star EV dealers informed of the model number, VIN number, estimated delivery time, contract number and date as well as a detailed description or photos of the faulty parts and problems, and our team will handle it accordingly.

Do not disassemble.

8: Electrical Diagrams

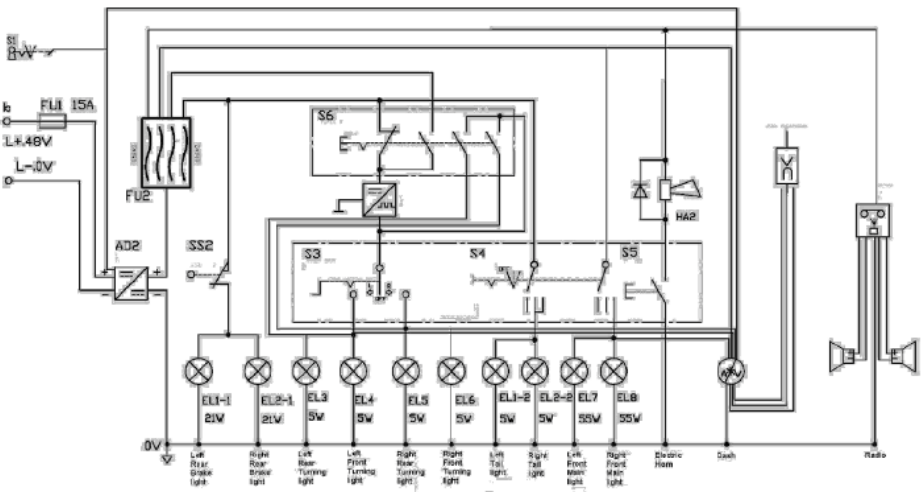

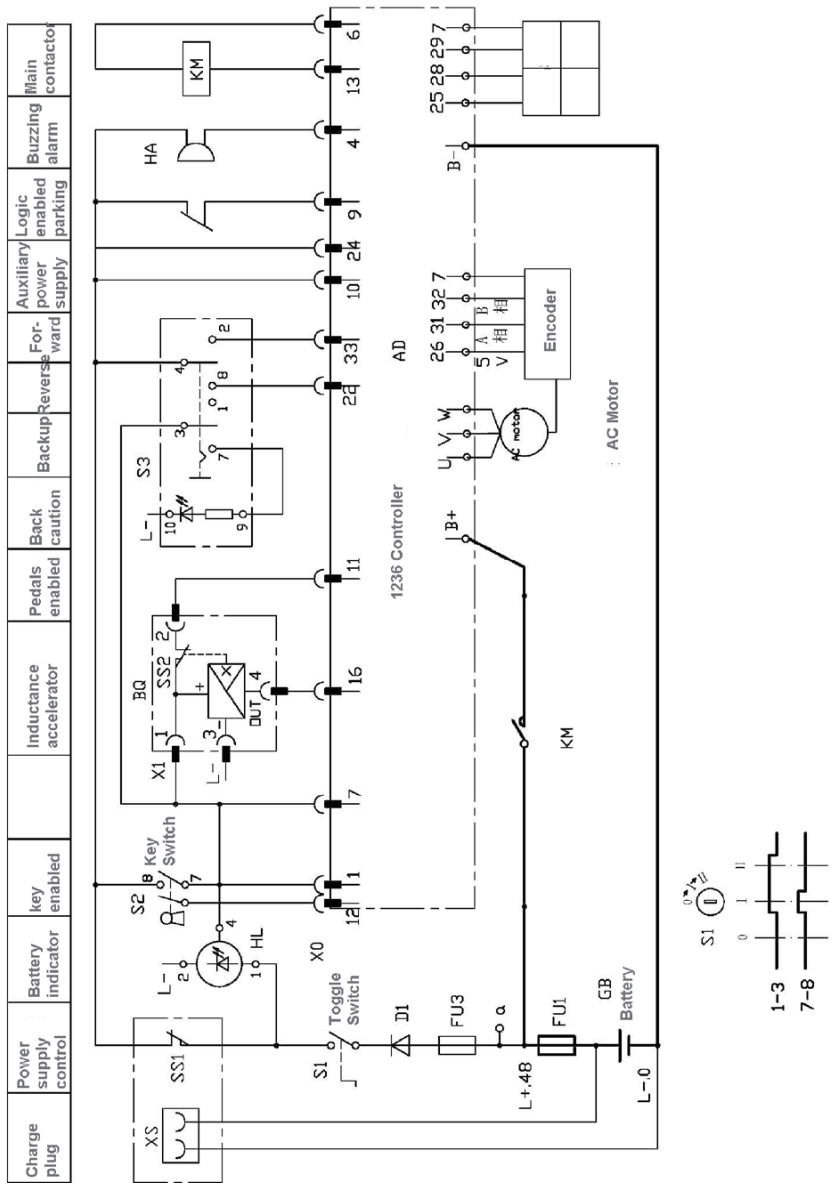

This manual tries to be as sound and elaborate as possible in literal and figurative description as well as technical description on the basis of existing data. At the same time, JH Global reserves the right to alter the content of this manual and this manual is subject to change without prior notice; in addition, JH Global has the final say on the interpretation of this manual.

All rights reserved.



ELECTRIC VEHICLES

STAR EV, a brand of JH Global Services, Inc.
378 Neely Ferry Road | Simpsonville, SC 29680
www.starev.com